

### GB with threaded flange (GB-M / GB-T) Product Brief

- ▶ Sensor element and electronics can be changed
- ▶ Available with threaded flange M18×1.5 or ¾"-16 UNF
- ▶ Electrical connection is freely rotatable

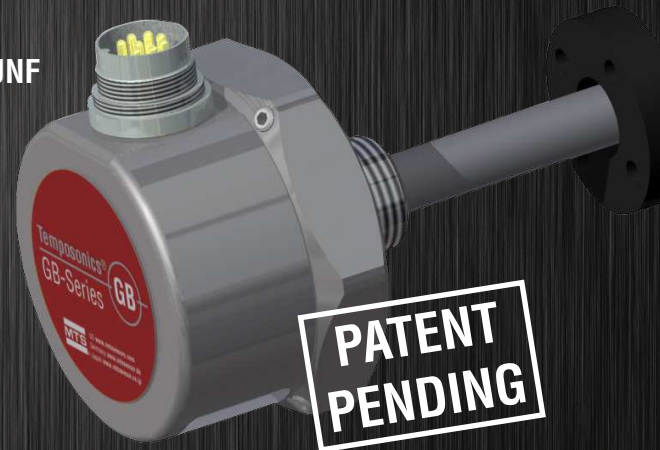

The Temposonics® GB-M / GB-T sensors, designed to be incorporated into hydraulic cylinders, offer many user-adaptable features. The flat and compact sensor electronics housing has an electrical connection that can be rotated 360 degrees to easily achieve the necessary connection orientation. If needed, the sensor element and electronics can be replaced without interrupting the hydraulic circuit – resulting in lower maintenance costs and reduced downtime.

The GB-Series is highly resistant to external influences and features a high pressure resistant sensor rod, electronics with excellent immunity to EMI and an operating temperature up to +100 °C.

GB sensors can be programmed via a wireless Bluetooth® connection, a computer with USB connection or a hand programmer. Output for data exchange is available in SSI and analog (current / voltage).

#### TYPICAL APPLICATIONS

Typical uses for GB sensors include steam turbines, valves for turbines and applications with limited space or high operating temperatures.

## TECHNICAL DRAWING

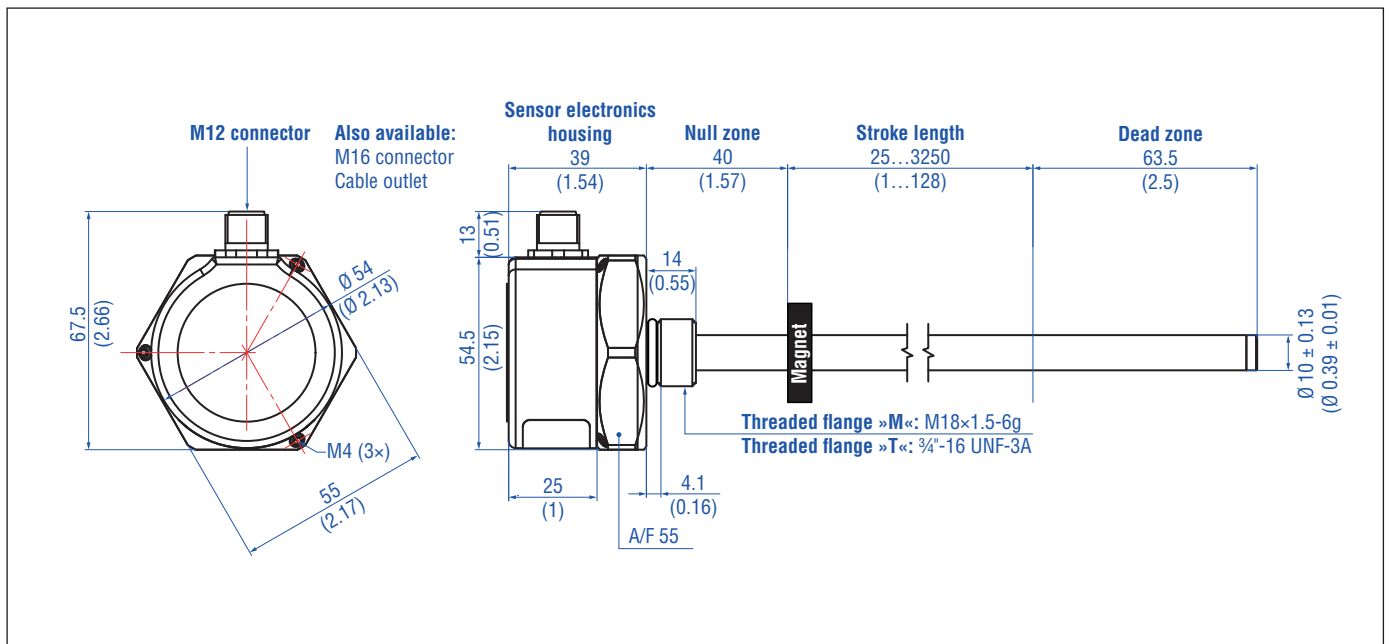

**Document Part Number:**  
551833 Revision B (EN) 06/2016

## LOCATIONS

**USA**  
**MTS Systems Corporation**  
Sensors Division  
3001 Sheldon Drive  
Cary, N.C. 27513, USA  
Tel. +1 919 677-0100  
Fax +1 919 677-0200  
info.us@mtssensors.com  
www.mtssensors.com

**JAPAN**  
**MTS Sensors Technology Corp.**  
737 Aihara-machi,  
Machida-shi,  
Tokyo 194-0211, Japan  
Tel. +81 42 775-3838  
Fax +81 42 775-5512  
info.jp@mtssensors.com  
www.mtssensors.com

**FRANCE**  
**MTS Systems SAS**  
Zone EUROPARC Bâtiment EXA 16  
16/18, rue Eugène Dupuis  
94046 Creteil, France  
Tel. +33 1 58 4390-28  
Fax +33 1 58 4390-03  
info.fr@mtssensors.com  
www.mtssensors.com

**GERMANY**  
**MTS Sensor Technologie**  
GmbH & Co. KG  
Auf dem Schüffel 9  
58513 Lüdenscheid, Germany  
Tel. +49 2351 9587-0  
Fax +49 2351 56491  
info.de@mtssensors.com  
www.mtssensors.com

**CHINA**  
**MTS Sensors**  
Room 504, Huajing Commercial Center,  
No. 188, North Qinzhou Road  
200233 Shanghai, China  
Tel. +86 21 6485 5800  
Fax +86 21 6495 6329  
info.cn@mtssensors.com  
www.mtssensors.com

**ITALY**  
**MTS Systems Srl**  
Sensor Division  
Via Camillo Golgi, 5/7  
25064 Gussago (BS), Italy  
Tel. +39 030 988 3819  
Fax +39 030 982 3359  
info.it@mtssensors.com  
www.mtssensors.com

## LEGAL NOTICES

MTS, Temposonics and Level Plus are registered trademarks of MTS Systems Corporation in the United States; MTS SENSORS and the MTS SENSORS logo are trademarks of MTS Systems Corporation within the United States. These trademarks may be protected in other countries. All other trademarks are the property of their respective owners. Copyright © 2017 MTS Systems Corporation. No license of any intellectual property rights is granted. MTS reserves the right to change the information within this document, change product designs, or withdraw products from availability for purchase without notice. Typographic and graphics errors or omissions are unintentional and subject to correction. Visit [www.mtssensors.com](http://www.mtssensors.com) for the latest product information.

ISO 9001  
CERTIFIED



MTS Sensors has a dedicated expert support team available to assist with your specific application needs. Contact an office in your region.